

# PDC-A 600/700

Automatic Double-Clipper



innovative · reliable · leading

**poly-clip**<sup>®</sup>  
SYSTEM

# PDC-A 600/700

- Fully automated
- Fast, quiet and operator friendly
- For all plastic, fibrous, collagen and natural casings
- EASY TOUCH for easy and comfortable operation
- Wide range of applications for calibres up to 105 mm

## Applications

The PDC-A 600 and PDC-A 700 automatic double-clippers are suitable for all sizes of operations – for mid-size or large production runs. They close any plastic, fibrous, collagen or natural casings. The PDC-A 600 processes even fibrous casings in diameter up to 65 mm and plastic casings up to 75 mm, while the PDC-A 700 closes fibrous up to 105 mm and plastic casings even above. Using the PDC-A means that all products – single portions or chains, long sausages, half rings and rings – can be produced efficiently.

## Advantages

- Fully automated operation for continuous production
- For all casings and all products - single portions, chains and rings
- High clipping speed
- Low-noise operation

Tape-less loops may be fed with the automatic looper GSE.

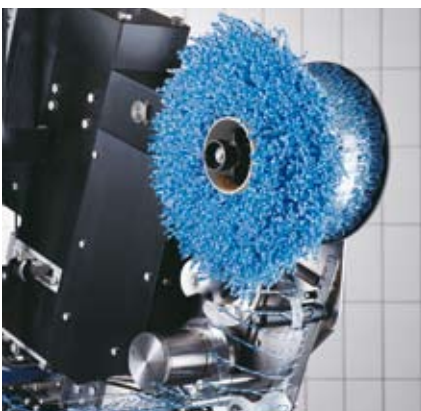

Rings, portions or chains – the PDC-A closes them all

- Hygiene:
  - made completely of stainless steel and industrial plastic
  - easy to clean due to smooth surfaces
- Robust construction
- Electronically controlled
- EASY TOUCH for easy and comfortable operation
- Product parameters available via programme memory
- EASY TOUCH settings:
  - control for chubs in a chain
  - loops
  - daily batch counter
- Space-saving: height-adjustable trolley fits to any existing table
- Pivoting clipping head for easy reload of casing
- Easy coupling to the filler: trolley for easy transport and fixing with lockable steering wheels
- Electrical and mechanical filler coupling
- Waterproof
- Pneumatic knife
- Upgrade to optional features on site

The separator is individually adjustable to every product generating an attractive appearance.

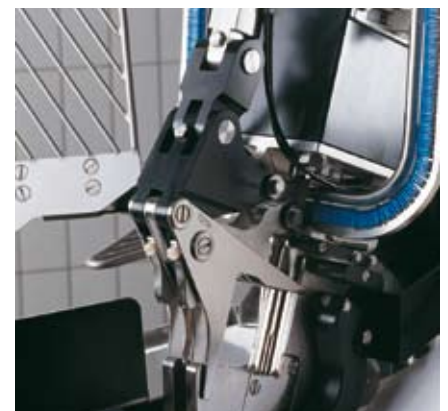



EASY TOUCH for easy and comfortable operation

### Optional equipment

- S-clips on spools
- String dispenser for rings
- Pneumatic casing brake holder movable
- Automatic looper (GSE) for tape-less loops
- Special lever for natural casings
- Labelling system ES 4000

### Function and operating

PDC-A 600 and PDC-A 700 automatic double-clippers can be coupled mechanically and electrically to the filler. When the operator closes the handle, the filled casing is centred, while separating the emulsion, and is securely closed with the double-clipping system. At the same time the casing can be cut off automatically with the pneumatic knife via the func-

With the PDC-A 700 fibrous casings up to a calibre of 105 mm are clipped quickly and reliably



The PDC-A automatic double-clipper reliably closes all artificial, fibrous, collagen and natural casings

tion of the chain control. For hanging-up the sausages, tape-less loops can be applied and clipped automatically with the optional looper.

EASY TOUCH means simple and convenient machine operation. The operating concept is based on a touch screen. The operator is guided intuitively through the flat menu structure with informative icons and can easily control the complete machine at the touch of a finger. The product programs' set of parameters can be very easily managed with EASY TOUCH and the machine settings speed up product change rapidly. Operator and service level are clearly separated from one another with the service level being password protected.

All Poly-clip System automatic double-clippers comply with the strict CE-regulations on hygiene, safety and ergonomics.

### Clip System Solutions

The complete machine, clip and loop system from one source ensures efficient, trouble-free production. The Original Clip from Poly-clip guarantees top quality. Manufactured to strictest quality standards, certified to ISO 9001:2000 and tuned precisely to the production process. The patented genuine, food-proof, safety coating using Poly-clip SAFE-COAT technology ensures trouble-free production and a no-worry product warranty. Poly-clip System is the world's leading provider of Clip System Solutions.

# PDC-A 600/700

Dimensions (in mm)

Technical data

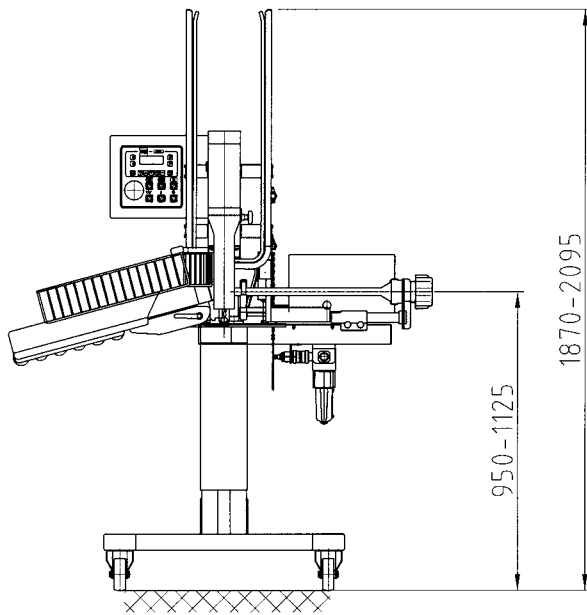

Front view

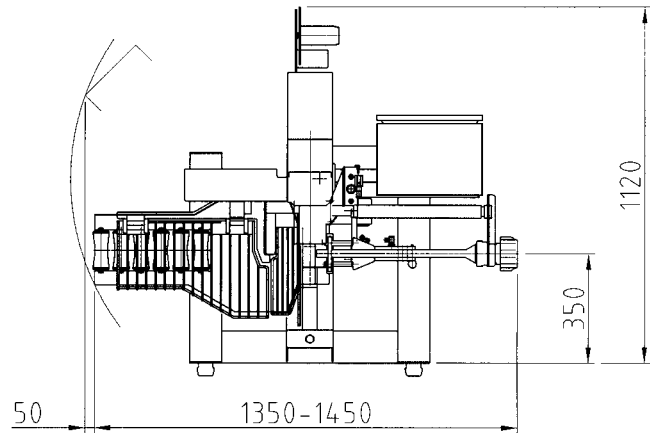

Top view

	PDC-A 600 (basic)	PDC-A 700 (basic)
Width:	1,000 mm	1,350 mm
Depth:	1,120 mm	1,120 mm
Height:	1,850 mm	1,870 mm
Weight:	130 kg	148 kg
Compressed air:	4-7 bar/0.4-0.7 MPa	4-7 bar/0.4-0.7 MPa
Three-phase current connection:	200-230 VAC, 380-460 VAC, 50/60 Hz	
Power input:	0.2 kW	0.2 kW
Fuse connection:	1 A	1 A
Air consumption:	12.9 NL/cycle	18.6 NL/cycle
Suitable clip-sizes:	S 625/628/632/638	S 735/740/744

PDC-A 600/700-GB-04/07-HA Subject to technical modifications.

**poly-clip**<sup>®</sup>  
SYSTEM